

# AIREA™ CO2 INCUBATOR

Advanced Controls, Smart Features, Versatile 6.75 cu ft Size

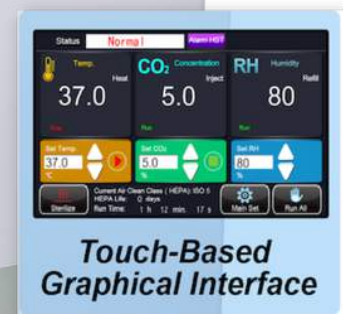

Touch-Based  
Graphical Interface



[Crystalindustries.com](http://Crystalindustries.com) | [Info@crystalindustries.com](mailto:Info@crystalindustries.com) | 972-934-2525



# AIREA™ CO2 INCUBATOR

The AIREA™ CO2 Incubator (CI-191CXA) is an air-jacketed, dry-wall insulation CO2 Incubator with temperature, CO2 concentration, and humidity functions. With this incubator, customers have the ability to visualize performance and data set on the AIREA™ Remote Monitoring accessory and app.

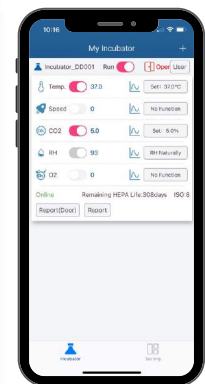
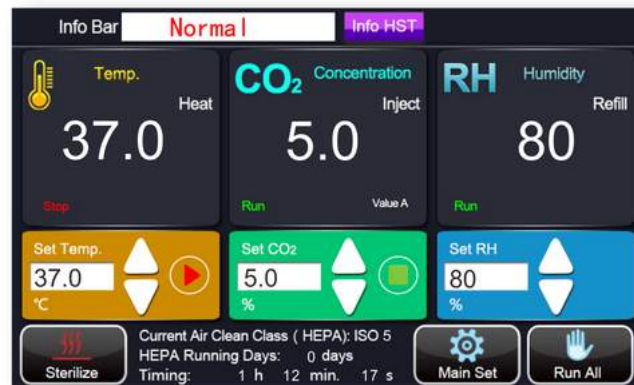

## PRODUCT FEATURES:

- Chamber HEPA air filtration provides class 100 purification
- Infra-Red (IR) sensor precisely and reliably detects CO2 concentration
- Easy sterilization process at 140°C dry heat
- Temperature controlled door prevents condensation and provides higher temperature stability and uniformity
- Intuitive 7" hi-res capacitive touchscreen
- Includes 4 shelves (can hold up to 13)
- Smart capabilities allow user to control CTI CO2 Incubator from a phone or tablet
- Visualize performance and changes over time with function performance graphs
- Audible and visual alarms alert user if parameters fluctuate outside set ranges
- 3 year warranty



# AIREA™ CO2 Incubator

## ACHIEVE OPTIMAL CELL GROWTH



### PRODUCT INFO

CI-191CXA is designed to best support a variety of cell cultures with its precise control of temperature and CO2 concentration. Smart capabilities in the touchscreen and remote monitoring accessory simplify the process of setting, adjusting, and monitoring parameters. The precise internal control of the AIREA™ CO2 Incubator takes the user's set parameters and creates accurate and optimal conditions for cell growth. The temperature uniformity and absence of condensation provided by the heated door also help ensure consistent results throughout the incubator's chamber. Reliable CO2 and humidity sensors deliver accurate readings and take the guesswork out of managing the environment of cell cultures.





# AIREA™ CO2 Incubator

## REMOTE MONITORING APP

Crystal Industries' AIREA™ Remote Monitoring accessory and app give customers the ability to control their CTI CO2 Incubator right from their phone or tablet via a Wi-Fi connection. Features of the Incubator app include the ability to set and change the incubator's parameters (including temperature and CO2 concentration). Text notifications are sent when an alarm is activated. This unique app makes it possible to stay conveniently connected with your CTI Incubator and ongoing projects, whether you are in the lab or not.

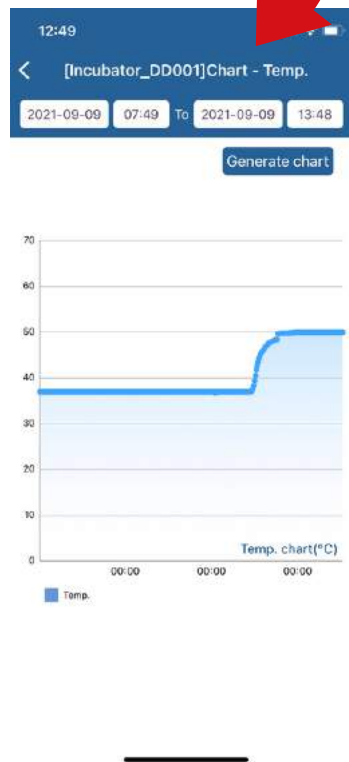
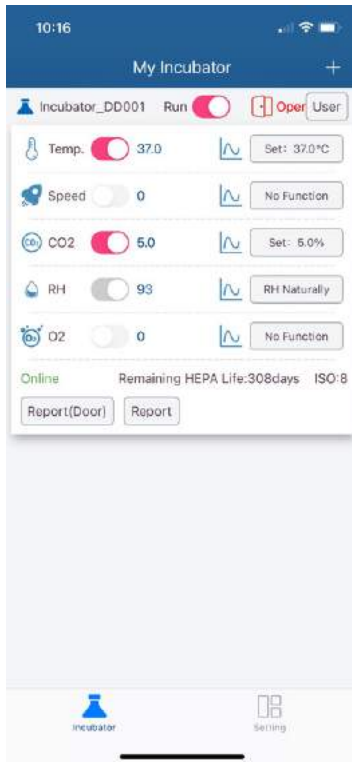

# AIREA™ CO2 Incubator

## TOUCHSCREEN DISPLAY

This touchscreen display is an intuitive and innovative user interface. On the main screen, parameters can be set, current values are displayed, and alarms will be displayed in real time. Customers can easily configure their setting preferences.

7" High-Res Color Touchscreen

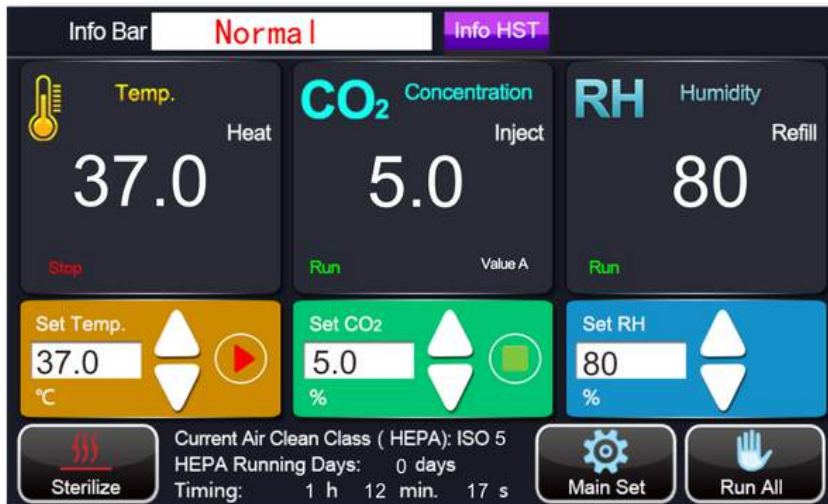



# AIREA™ CO2 Incubator

## PRODUCT SPECIFICATIONS

Model	CI-191CXA
Product Name	AIREA™ CO2 Incubator 191L, Air Jacket, Dry Heat Sterilization, Touch Screen
Capacity	191 L (6.75 cu ft)
Temperature Range	Room Temp.+5°C - 60°C
Temperature Accuracy	±0.1°C (@ 37°C) ±0.3°C max
Temperature Uniformity	±0.3°C (@ 37°C) ±0.6°C max
Temperature Stability	±0.2°C (@ 37°C) ±0.4°C max
CO2 Sensor	Infrared
CO2 Concentration Range	0% - 20%
CO2 Concentration Accuracy	±0.1%
Relative Humidity Type	Natural Evaporation from Humidity Pan
Max Humidity	95% @ 37°C
Humidity Pan Volume	3 L
Sterilization	140°C Dry Heat Sterilization
Sterilization Time	12 Hours
Temperature Recovery Time After Door is Open for 30s	≤6min (@ 37°C)
CO2 Concentration Recovery Time After Door is Open for 30s	6 min (@ 5%)
Chamber Air Purity	Chamber HEPA Filter Creates Class 100 Environment
Shelf Dimensions	472 x 472 mm 18.58 x 18.58 in
Standard Number of Shelves	4
Max Number of Shelves	13
Max Load per Shelf (When slid in and out)	15 kg (33.06 lb)
Max Load per Shelf (Stationary)	20 kg (40.09 lb)
Chamber Dimensions (DxWxH)	540 x 510 x 700 mm 21.26 x 20.08 x 27.56 in
Outer Dimensions (DxWxH)	671 x 699.5 x 1012 mm 26.42 x 27.54 x 39.84 in
Net Weight	125 kg (276 lb)
Door Opening Direction	Rightward
Insulation	Dry-Wall
User Interface	7 inch Color Touch Screen
Data Stored	Time, Temperature, CO2 Concentration, Humidity, Instrument Status
Screen Data Display	Displays Most Recent 7 Days of Data
USB Data Export	Most Recent 912 Days of Data
Parameter Protection	Optional Touchscreen Password Protection
Abnormal Temperature Alarm	Adjustable
Abnormal CO2 Concentration Alarm	Adjustable
Abnormal Humidity Alarm	Adjustable
Noise Level	≤53 dB
Mobil Monitoring via Wifi	Optional through a Wifi connecting accessory (CIA19) and smart phone app
Auto- Recovery After Power Disruption	Yes
Power	≤1100 W
Power Supply	AC 110 V / 60 Hz
Certifications	CE



# AIREA™ CO2 Incubator

## PRODUCT DIMENSIONS

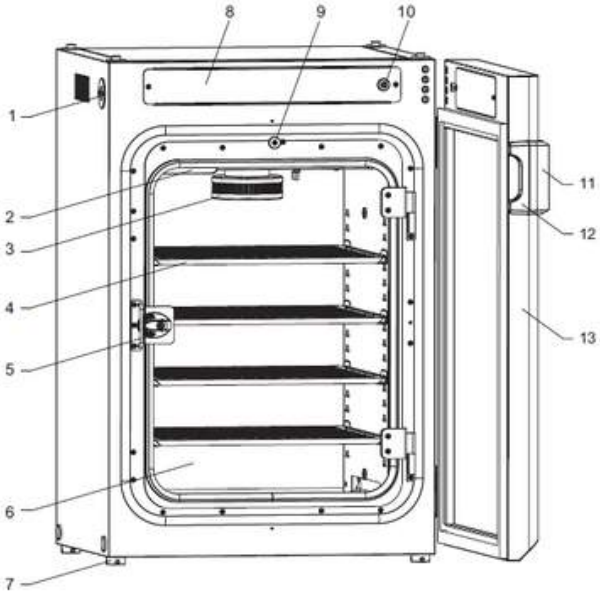

- 1---Air Sample Hole
- 2---CO2 Sensor Box
- 3---HEPA Filter
- 4---Shelf
- 5---Inner Door Latch
- 6---Inner Door
- 7---Foot
- 8---Control Assembly
- 9---Inner Door Sensor
- 10---Outer Door Sensor
- 11---Touchscreen
- 12---Outer Door Handle
- 13---Outer Door

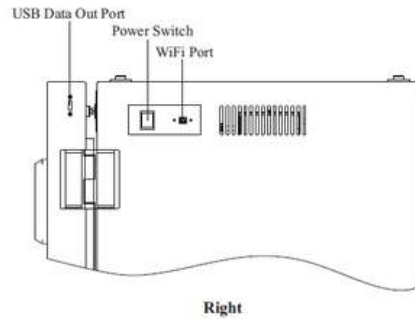
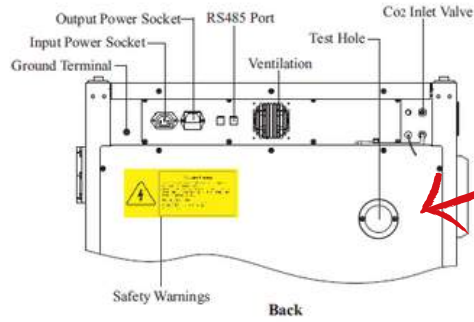

Convenient connection port for utilizing Mixers, Rollers, and Shakers inside this Airea CO2 Incubator.



### Door Open

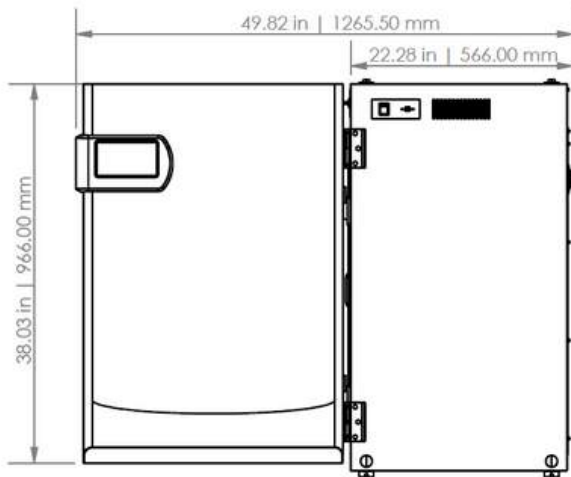

### Double Stack

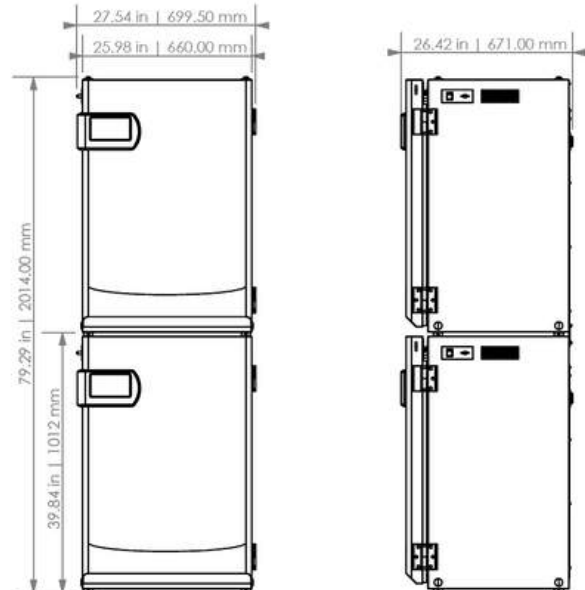



# AIREA™ CO2 Incubator

## PRODUCT ACCESSORIES



CO2 Inlet HEPA Filter  
1 Year Service Life  
Model: CIA15



Remote Monitoring for  
CO2 Incubator  
Model: CIA19



Shelves  
CO2 Incubator  
Model: CIA24



Chamber HEPA Filter  
1 Year Service Life  
Model: CIA13



Caster Wheels  
Model: CIA28



CO2 Cylinder Pressure Regulator  
Model: CIA25





# AIREA™ CO2 Incubator

Advanced Controls, Smart Features, Versatile 6.75 cu ft Size



*For over 25 years Crystal Technology and Industries has been driven to deliver exceptional value to the scientific marketplace by developing innovative equipment and Cryo Storage Solutions for today's scientist.*